

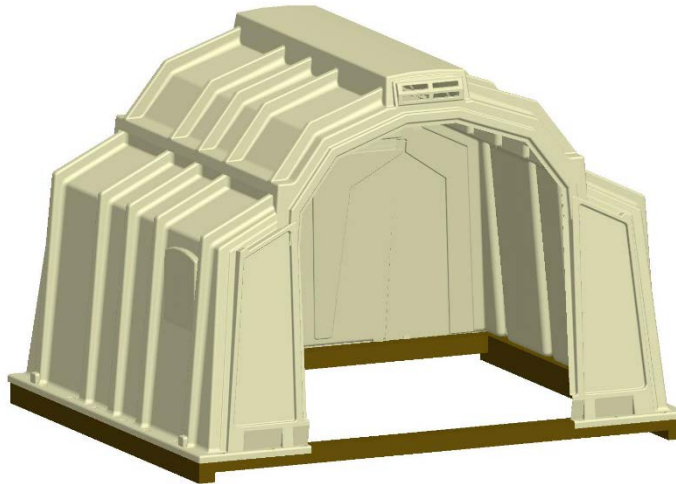

54|98 Assembly Instructions



Bill of Material:

Item	Hampel Item Number	Description	Qty
1	AH-110-1	Top Cap	1
2	AH-135-L	Left Side	1
3	AH-135-R	Right Side	1
4	AH-220	Back Panel, W/Bedding Door	1
5	AH-151	Knockdown Hardware Kit	1
6	CH-9225	Parts Kit, Warm Weather Latch	2
7	CT-10037	Bracket – Bedding Door Reinforcement	2
8	CT-HDWE-037	Hardware Kit – Bedding Door Reinforcement	2
Optional Item –Lumber Kit			
10	AH-LUMBER-KIT (includes below items)	Wood & Hardware for Mounting Hutch	1
	AH-150-1	Bolts and Washers Kit for Mounting Hutch	1
	AH-LUMBER-002-1	Runner, 54 98 Base	2
	AH-LUMBER-001-1	Side, 54 98 Base	2

Tools Needed – To Assemble the Unit:

1. ¼" (6mm) Drill Bit
2. Drill
3. 5mm Socket
4. Ratchet
5. Helper(s)

Tools Needed – To Assemble the Latch:

1. 7/16" or 11mm Socket / Ratchet
2. 7/16" or 11mm Wrench



Step 1: Assembling the 54|98

- A. First - Place the Left and Right Sides of the 54|98 on the ground standing upright approx. 60" (1524mm) apart. (as shown in the picture below)

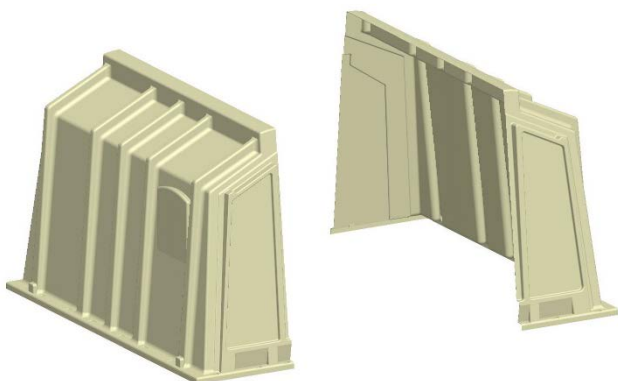

****Optional Method****

Sides may be slightly warped due to shipment configuration. It may help to attach the two (2) sides to the wood base prior to assembling the 54|98. (see picture below)

Follow the steps at the end of these instructions ...**(Optional Item – Lumber Kit)**... to assemble the wood base to the Sides of the 54|98 using the provided screws and washers. This will hold the Sides in place so the next Steps will be easier to accomplish.

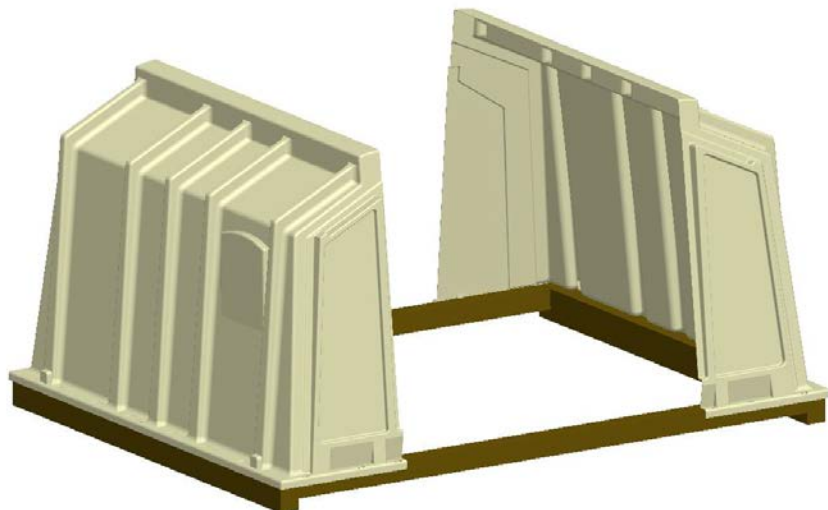



- B.** Next – Place the Top Cap onto the Left and Ride Sides...the sides may need to be adjusted so the Top Cap sits correctly. The ribs on the Top Cap should line up with the ribs on the sides. (as shown in the pictures below)

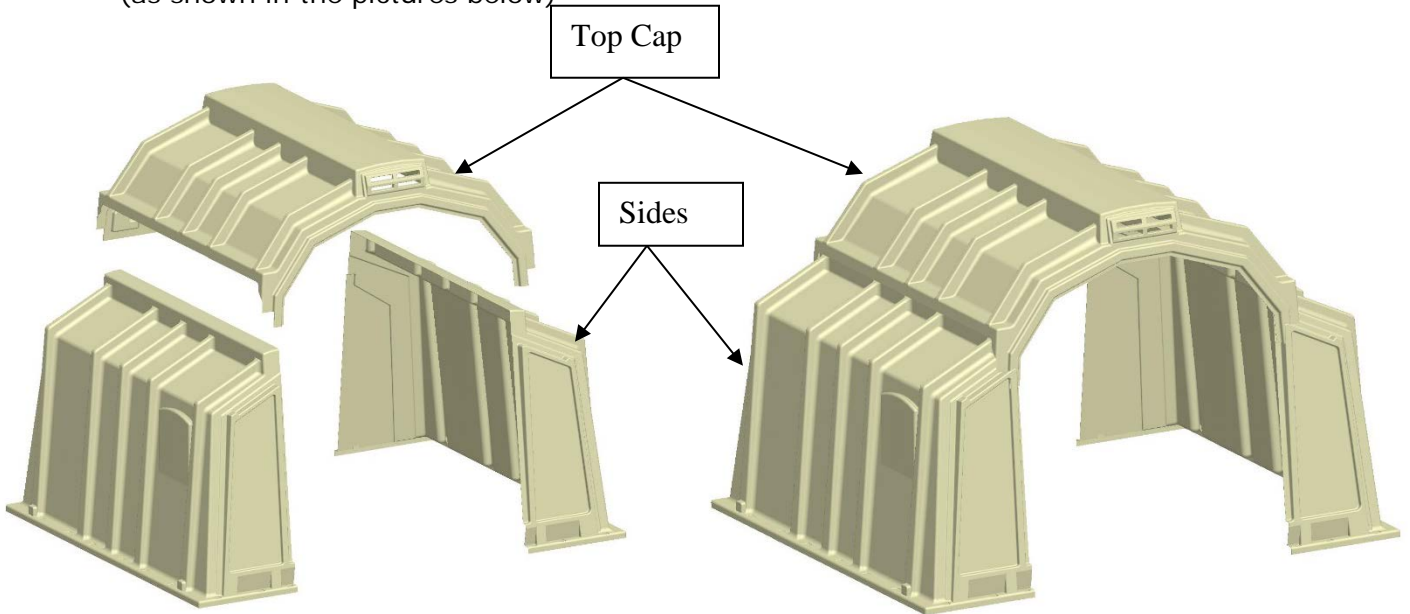

- C.** Next – Starting in the back corner, attach the Top Cap to the Left and Right Side using the M5 Bolt, Washers and Lock Nut. Using the 1/4" (6mm) drill bit, locate the predrilled holes in the Top Cap and use them to drill a hole thru the Sides.

- i. The rivet is inserted from the outside of the 54|98 and the backup washer is used on the inside of the 54|98. (see detail below)

Start Attaching Here
(7 per side)

Insert a bolt with a washer
from the outside and attach
a washer and nut from the
inside.

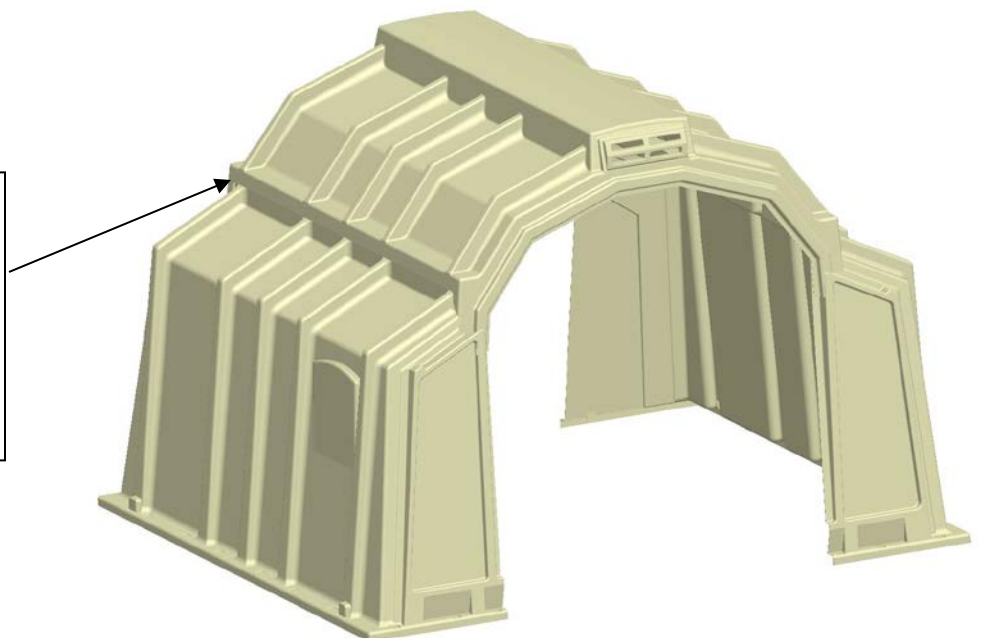



- D. Next – Attach the Back of the 54|98 using the 1/4" (6mm) Rivets and Back Up Washers. Using the 1/4" (6mm) drill bit, locate the predrilled holes in the Back and use them to drill a hole thru the Sides. The Back slides up under the Top Cap and over the top of the Sides.

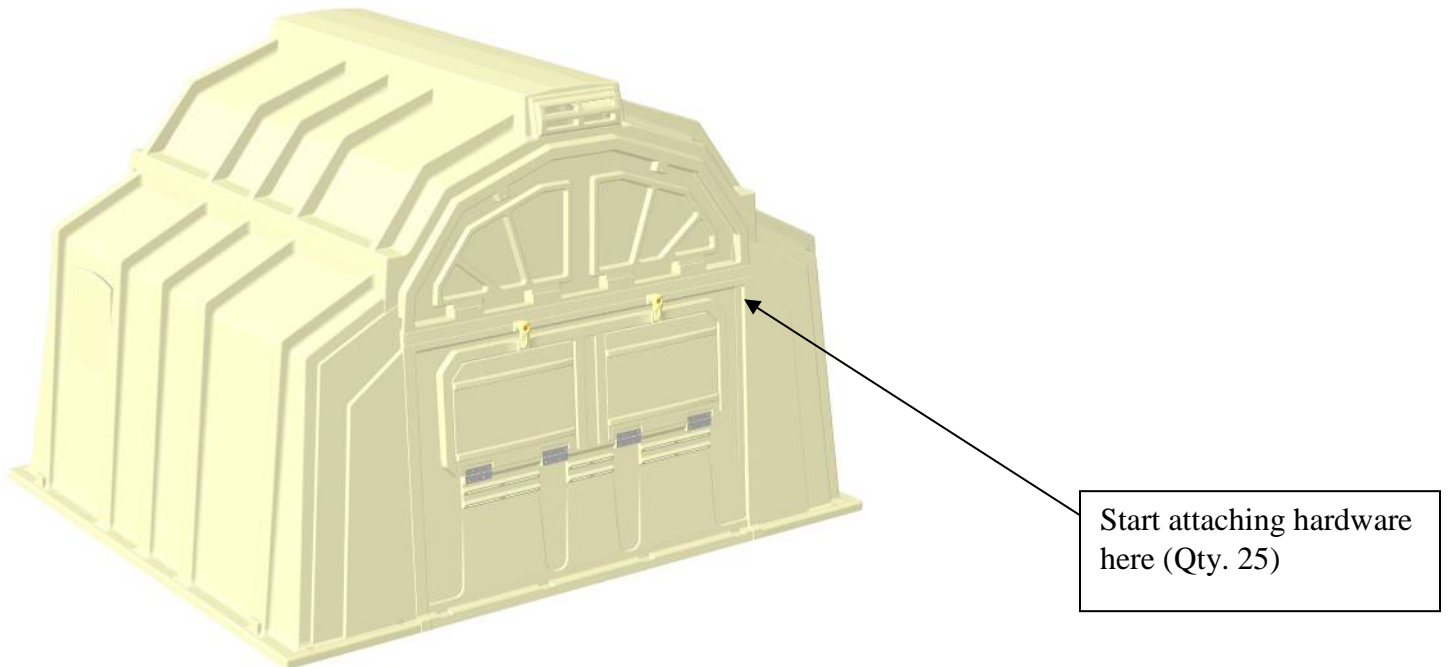
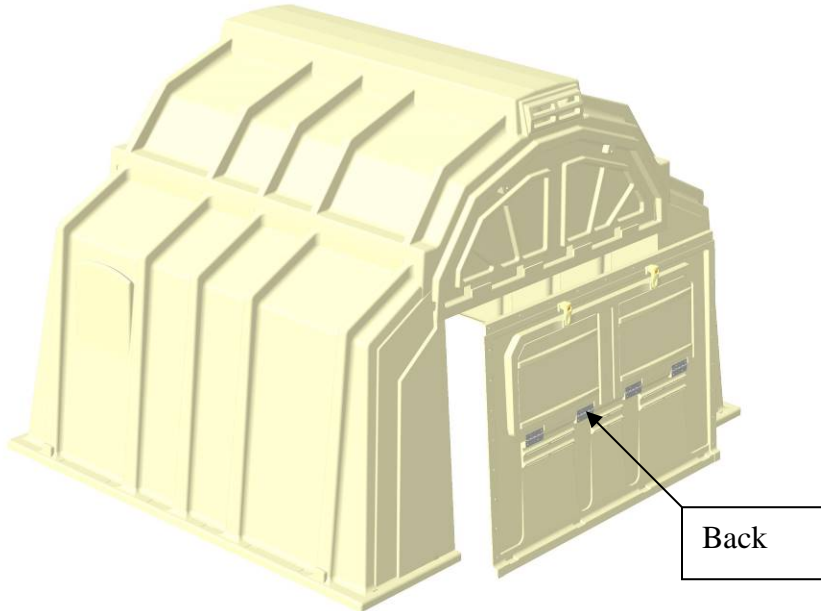



Reinforcement Bracket

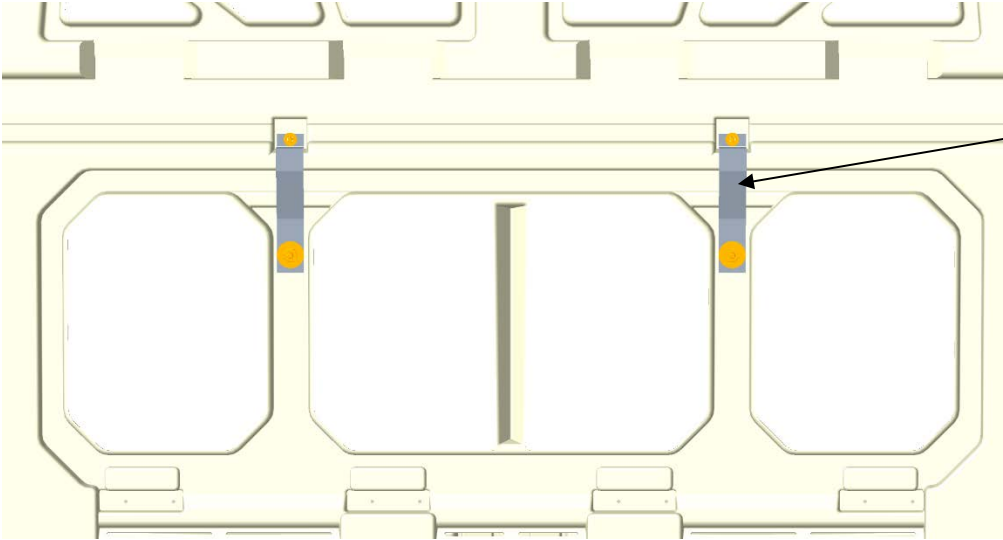

Reinforcement Bracket Installed in 2 locations on the inside of the unit using CT-10037 and CT-HDWE-037.

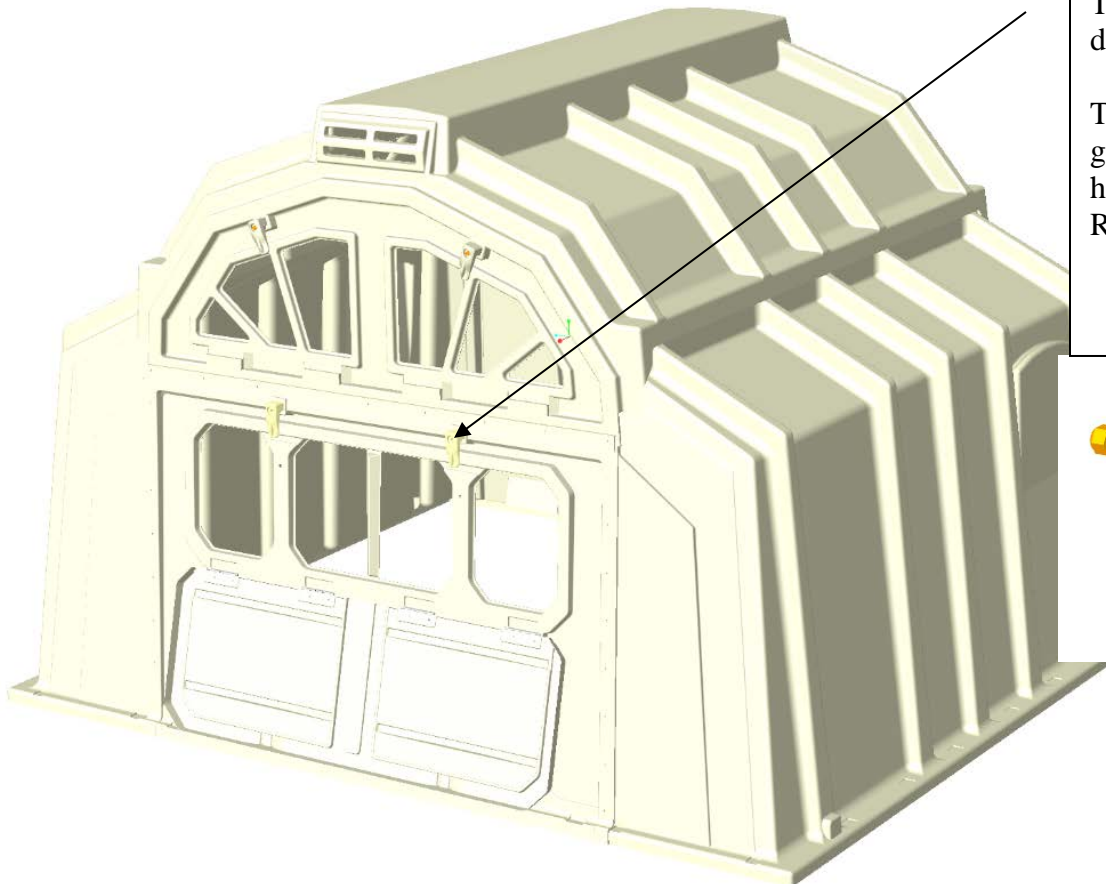

Assemble the CH-9225 Latch to the AH-220 Back Panel in 2 Places. This locks the bedding door closed.

The CH-9225 hardware goes through the upper hole in the Reinforcement Bracket.

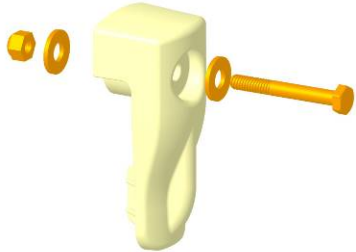

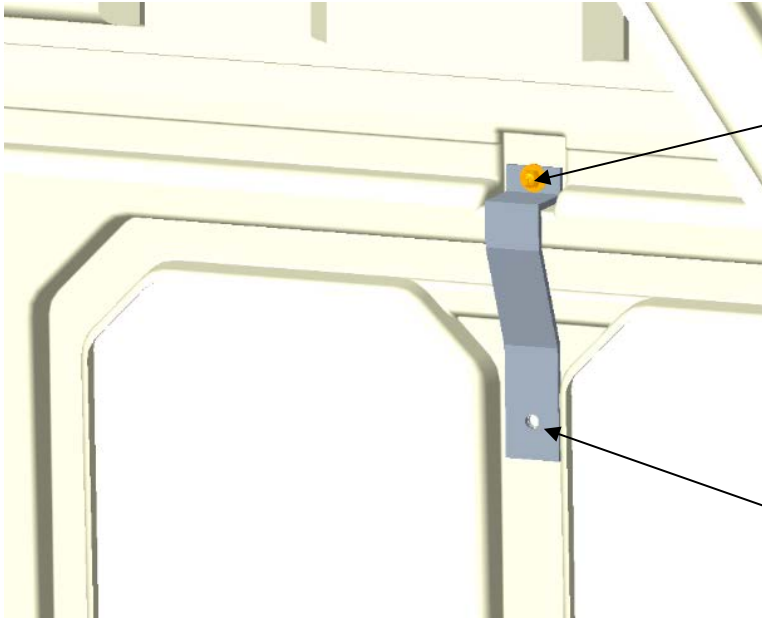

Install Reinforcement Bracket (CT-10037) as shown and reinstall nut and washer to Latch.

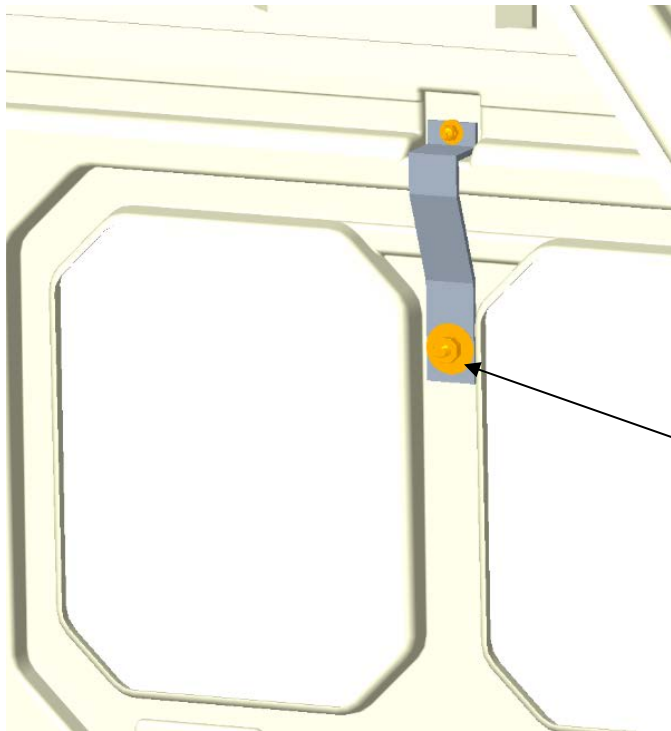

Using a 5/16" dia drill bit, drill a hole through the plastic using the hole in the Reinforcement Bracket as a guide.

Attach Bracket to plastic with the CT-HDWE-037 hardware kit. Insert bolt from outside using a washer and tighten the nut on the inside.



Optional Item – Rear Upper Door Latch

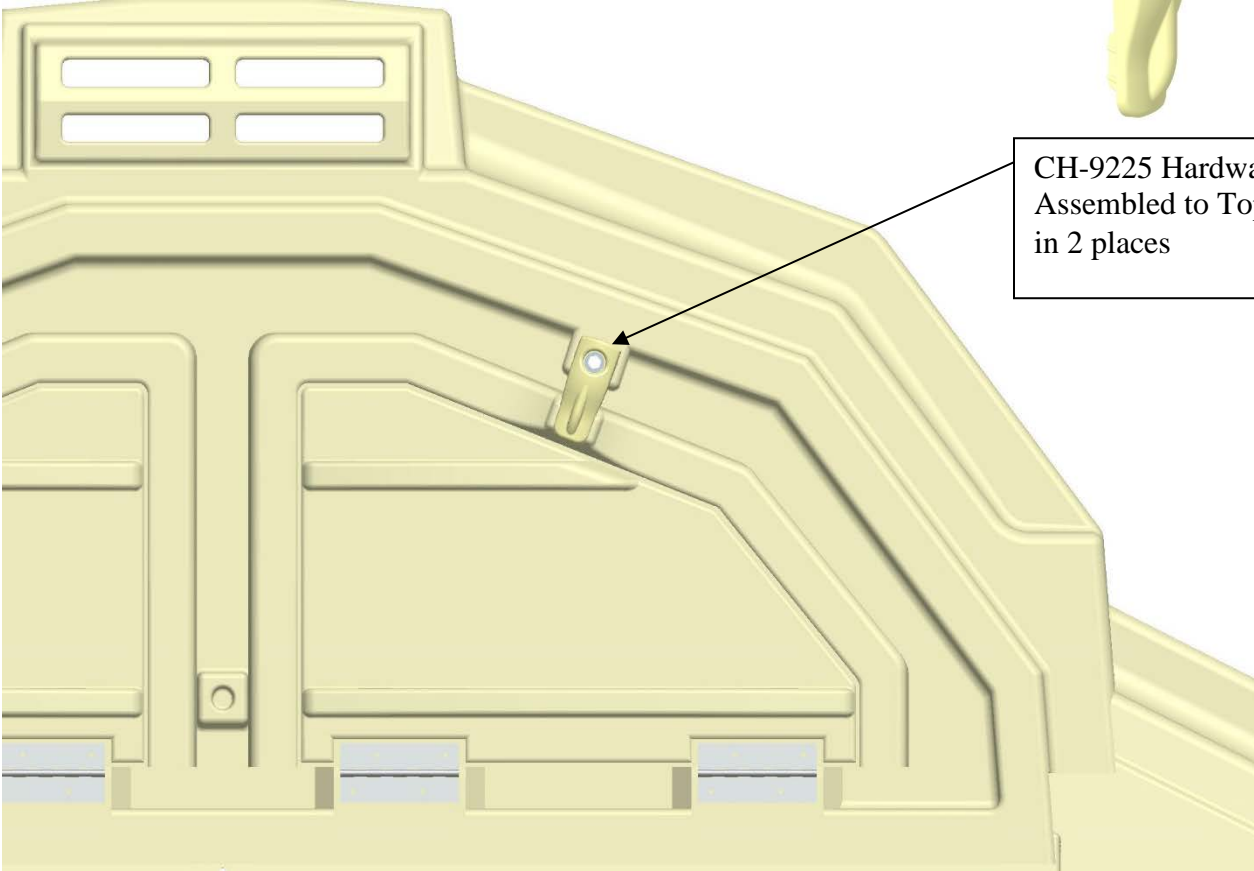

CH-9225 Hardware Kit
Assembled to Top Cap
in 2 places



Optional Item – Lumber Kit

Step 1. Base Lumber Kit

Lumber size:

- 2 pcs - 4" x 4" x 99.125" (101.6mm x 101.6mm x 2517.7)
- 2 pcs – 4" x 6" x 88.125" (101.6mm x 152.4mm x 2136.7)

- A. Using 13/64" (5mm) Drill Bit, drill (8) pilot holes. Repeat for all 4 corners (See Figure 1)

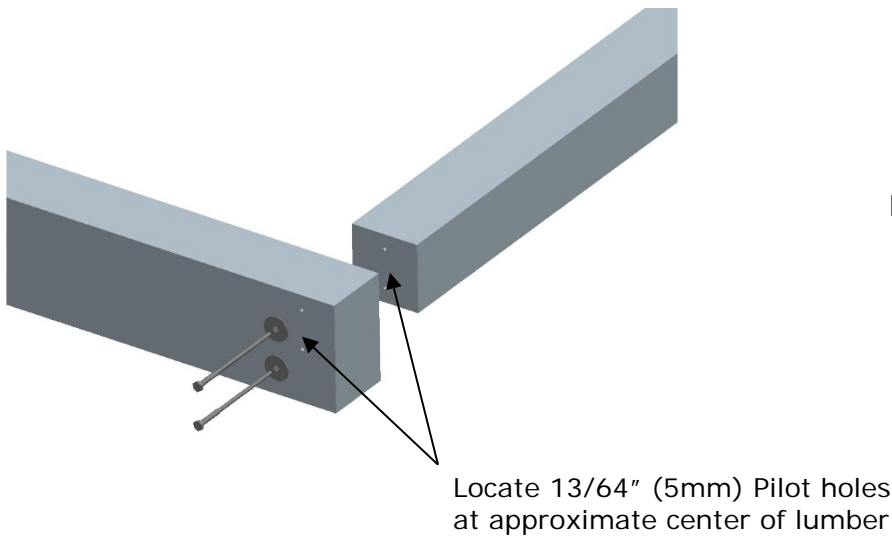

Figure 1

Step 2: Assemble Base

- A. Using 5/16" (8mm) Deep Well Socket, assemble lumber using (2) 1" (25.4mm) washers with (2) 5-1/2 x 1/4 (139.7mm x 6mm) Lag Screws. Repeat for all 4 corners (See Figure 1)

Step 3: Assemble Base to Hutch

- A. Using 5/16" (8mm) Deep Well Socket, washers and screws, fasten (2) brackets (included in hardware kit) near entrance securing Hutch to Base (see figure 2)
- B. Fasten Hutch to Base at remaining locations around perimeter using washers and screws.

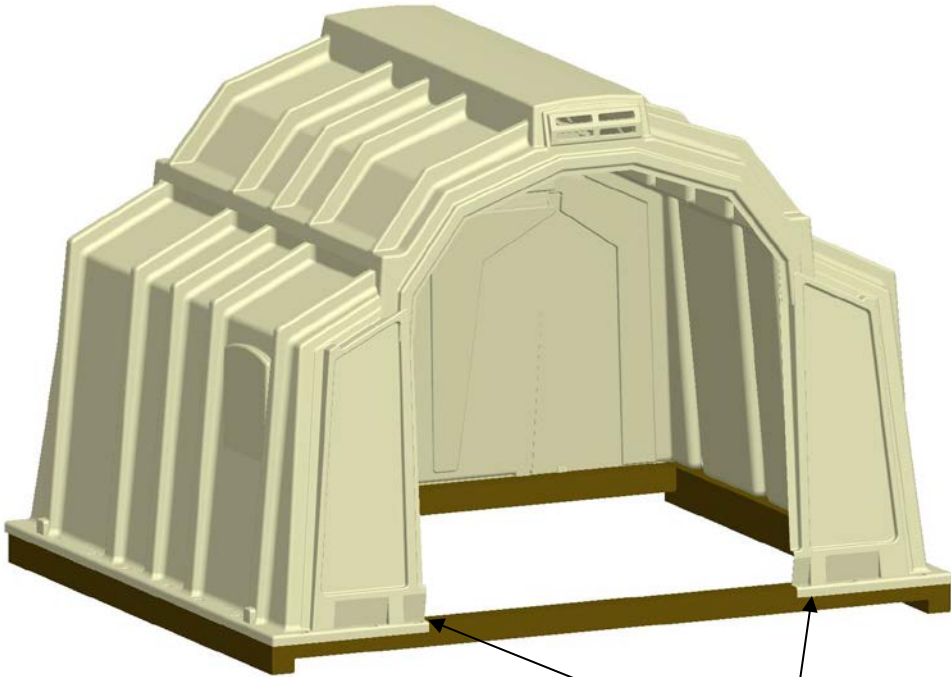

Figure 2

Entrance bracket attachment locations.